

CE CERTIFIED EXTERNAL ACCESS SYSTEM FOR MEGAYACHTS



This safe, secure system provides freedom of movement and the ability to lock yourself in one position as you work outboard along the hull.

STRONG, SMOOTH-ROLLING CARS

Cars are constructed of strong, lightweight one-piece solid aluminum. Torlon® ball bearings handle high loads, reducing friction to move you smoothly along the track as you change the locking pinstop to another position. Bearings do not corrode.

CE Certified and tested to: EN795.1996 Class D

LONG-LASTING PROTECTIVE FINISH

Cars and track come in black Hardkote or clear-coat anodized finishes for corrosion protection, durability, and to match the aesthetics of your megayacht. Stainless steel system can be special ordered through the Harken Custom Department.

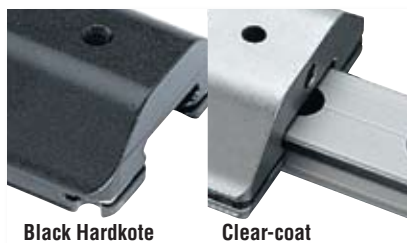

Black Hardkote

Clear-coat



Pinstop car allows movement of cars along track. Open to move; close to lock in place.



Stainless steel wire guides keep the ball bearings captive when cars are off the track for easy maintenance.

CE CERTIFIED
HARKEN®

CE CERTIFIED EXTERNAL ACCESS SYSTEM

REQUIRED SYSTEM COMPONENTS

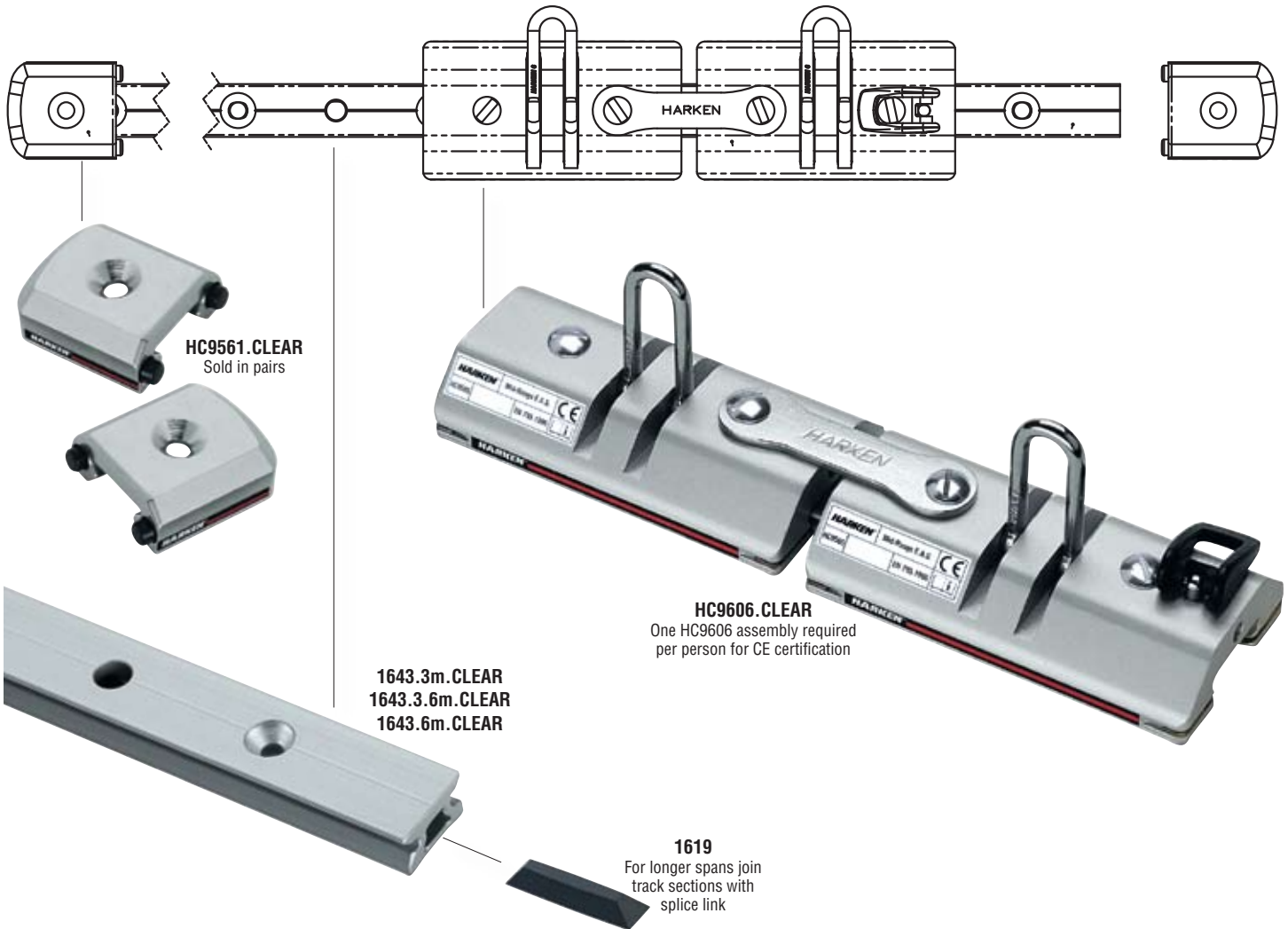

HC9561.CLEAR
Sold in pairs

HC9606.CLEAR
One HC9606 assembly required
per person for CE certification

1643.3m.CLEAR
1643.3.6m.CLEAR
1643.6m.CLEAR

1619
For longer spans join
track sections with
splice link

Car Assembly

Part No.	Description	Length		Width		Maximum working load		Fits track
		in	mm	in	mm	lb	kg	
HC9606.CLEAR*	Midrange 2-car external access car assembly with coupler	10 ³ / ₄	273	2 ³ / ₄	70	220	100	1643.3m.CLEAR*

*To order black Hardkote-anodized, remove ".CLEAR" from end of part number

Track

Part No.	Description	Length		Mounting hole spacing		Fasteners		Endstop	Splice link
		ft/in	m	in	mm	in	mm		
1643.3m.CLEAR*	Midrange high-load pinstop track	9'10 ¹ / ₁₆ "	3	3 ¹⁵ / ₁₆	100	⁵ / ₁₆ FH	8 FH	HC9561.CLEAR*	1619
1643.3.6m.CLEAR*	Midrange high-load pinstop track	11'9 ⁹ / ₄ "	3.6	3 ¹⁵ / ₁₆	100	⁵ / ₁₆ FH	8 FH	HC9561.CLEAR*	1619
1643.6m.CLEAR*	Midrange high-load pinstop track	19'8 ¹ / ₄ "	6	3 ¹⁵ / ₁₆	100	⁵ / ₁₆ FH	8 FH	HC9561.CLEAR*	1619
HC9561.CLEAR*	Midrange track endstops (sold in pairs)	2 ¹ / ₄ "	57 mm	—	—	⁵ / ₁₆ FH	8 FH	—	—
1619	Splice link	Purchase one splice link for each track section.							

*To order black Hardkote-anodized, remove ".CLEAR" from end of part number

CE CERTIFIED EXTERNAL ACCESS SYSTEM

SUGGESTED SUPPORT SYSTEM & OPTIONS

ATTACHMENT OPTIONS

Track and cars can be mounted to slide from multiple positions:



Mounted on vertical plane: cars face outward



Mounted on horizontal plane: cars face down

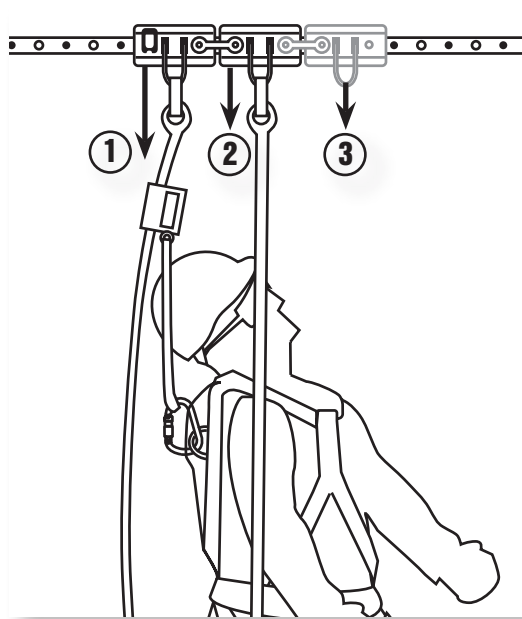

REQUIRED SYSTEM CONFIGURATION

1. Full-Body Safety Harness

Use a full-body safety harness attached to the HC9606 access car with pinstop.

Full-body safety harness must meet CE/ANSI support standards.

2. Working Harness

Use a working harness or chair attached to the HC9606 access car without pinstop.

Working harness or chair must meet CE/ANSI support standards.

ADDITIONAL OPTIONS

3. Tool Service Car

Add an optional HC9565 pinstop car or HC9608 car with H-50547 coupler to work as your tool service carrier.



HC9565.CLEAR



HC9608.CLEAR



H-50547

Optional Parts

Part No.	Description	Length		Width		Maximum working load		Fits track
		in	mm	in	mm	lb	kg	
HC9565.CLEAR*	Midrange external access car with pinstop	5 ³ / ₁₆	132	2 ³ / ₄	70	220	100	1643.3m.CLEAR*
HC9608.CLEAR*	Midrange external access car	5 ³ / ₁₆	132	2 ³ / ₄	70	220	100	1643.3m.CLEAR*
H-50547	Car coupler	3 ⁹ / ₁₆	90	1	25	—	—	—

*To order black Hardkote-anodized, remove ".CLEAR" from end of part number

HARKEN®

Harken Manufacturing: 1251 E. Wisconsin Ave., Pewaukee, WI 53072 USA • Tel: 262-691-3320 • Fax: 262-691-3008 • Email: harken@harken.com • Web: www.harken.com

E.U. Representative: Harken UK Ltd., Bearing House, Ampress Lane, Lympington, Hampshire SO41 8LW, England • Tel: (44) 01590-689122 • Fax: (44) 01590-610274 • Email: enquiries@harken.co.uk • Web: www.harken.co.uk • 071509